

Weights

Operating weight with cab and bucket (ISO 6016)	3476 kg
Transport mass (no attachment)	3312 kg
Weight reduction with canopy	-118 kg
Additional weight for cab with HVAC	19 kg
Additional weight for steel tracks	94 kg
Additional weight for long dipperstick	12 kg
Additional weight for heavy counterweight	291 kg
Ground pressure with rubber tracks	33.60 kPa

Engine

Make / model	Kubota / D1703-E4B (Stage V)
Fuel	Diesel
Number of cylinders	3
Displacement	1642 cm ³
Maximum power @ 2200 rpm (ISO 14396)	18.2 kW
Maximum torque (SAE)	97.4 Nm

Hydraulic System

Pump type	Single outlet variable displacement, load sensing torque pump with gear pumps
Total hydraulic capacity	101.20 L/min
Auxiliary (AUX1) flow	64.00 L/min
Auxiliary (AUX2) flow	20.00 L/min
Auxiliary (AUX1) relief	206.00 bar
Auxiliary (AUX2) relief	179.00 bar

Performance

Digging force, dipperstick (ISO 6015)	20790 N
Digging force, long dipperstick (ISO 6015)	18010 N
Digging force, bucket (ISO 6015)	33430 N
Drawbar pull	34132 N
Travel speed, low range	2.6 km/h
Travel speed, high range	4.7 km/h

Slew System

Boom swing, left	75.0°
Boom swing, right	55.0°
Slew rate	8.6 RPM

Fluid Capacities

Fuel reservoir	52.00 L
Hydraulic reservoir	8.30 L

Environmental

Noise level LpA(EU Directive 2006/42/EC)	77 dB(A)
Noise level LWA(EU Directive 2000/14/EC)	94 dB(A)
Whole body vibration (ISO 2631-1)	0.11 ms ⁻²
Hand-arm vibration (ISO 5349-1)	0.34 ms ⁻²

Standard Features

1550 mm dozer blade	Horn
300 mm rubber tracks	Hydraulic joystick controls
Adjustable double acting auxiliary hydraulic (AUX1) with Quick Couplers	Proportional fingertip auxiliary and boom swing offset hydraulic control
Battery disconnect switch	Retractable seat belt
Blade float feature	Suspension seat with high back
Clamp ready	Storage compartment
Control console locks	TOPS/ROPS/FOPS canopy * 1
Cupholder	Two-speed travel with Auto shift
Dual Direction Detent	Upper structure four-point tie down
Engine/hydraulic monitor with shutdown	Water separator
Foldable and ergonomic pedals	Work light (boom)
Full fuel warning alarm	Warranty: 24 months, 2000 hours (whichever occurs first)

1. Roll Over Protective Structure (ROPS) – Meets requirements of ISO 3471. Tip Over Protective Structure (TOPS) – Meets requirements of ISO 12117. Falling Object Protective Structure (FOPS) - Meets requirements of ISO 3449.

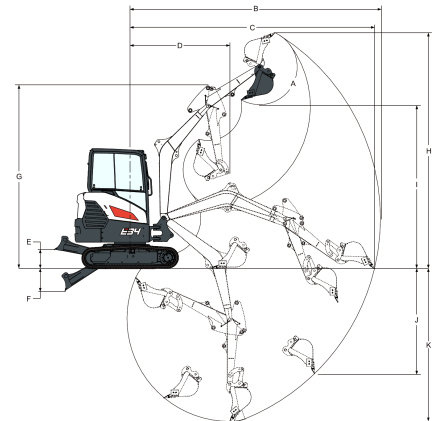
Working Range

Values marked with * - Long dipperstick

(A)	185.0°	(G)	3708.0 mm
(B)	5101.0 mm	(H)	4804.0 mm
(B)	5383.0 mm	(H*)	4985.0 mm
(C)	4980.0 mm	(I)	3340.0 mm
(C*)	5270.0 mm	(I*)	3521.0 mm
(D)	2017.0 mm	(J)	2136.0 mm
(D*)	2077.0 mm	(J)	2414.0 mm
(E)	382.0 mm	(K)	3117.0 mm
(F)	456.0 mm	(K*)	3417.0 mm

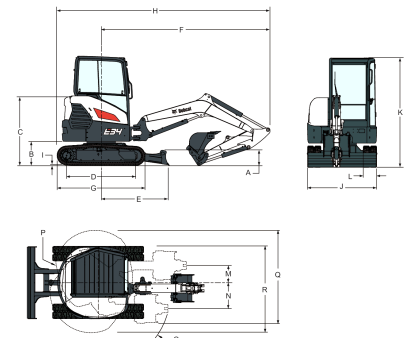
Dimensions

Values marked with * - Long dipperstick

(A)	322.0 mm	(J)	1550.0 mm
(B)	540.0 mm	(K)	2468.0 mm
(C)	1557.0 mm	(L)	300.0 mm
(D)	1542.0 mm	(M)	371.0 mm
(E)	1528.0 mm	(N)	554.0 mm
(F)	3787.0 mm	(O)	1623.0 mm
(G)	1970.0 mm	(P)	1125.0 mm
(H)	4661.0 mm	(P*)	1215.0 mm
(H*)	4761.0 mm	(Q)	1982.0 mm
(I)	25.0 mm	(R)	1855.0 mm

Options

Comfort package cab (Cloth susp. seat & Dlx displ.)	Auto idle
A-SAC package (Tilt coupler lines, Dlx displ.)	Keyless ignition
Object handling package (Valves, OWD, Lifteye)	Travel motion alarm
TOPS/ROPS/FOPS cab	AM/FM MP3 radio
Long dipperstick	Additional halogen lights
Heavy counterweight	LED lights set
Steel tracks	Beacon
AUX1 direct return to tank	Special application kit
AUX2 hydraulics	L/R mirrors
AUX1/AUX2/Drain on arm	Clamp w/ AUX1 valve
Bucket valves (AUX3) kit	Klacc D and MS03 coupler
Hydr. coupler lines (AUX5)	Bobcat hydr. pin grabber
Case drain line	Grease Gun w/ holder